



APPUNTS VELO

- Ligne 100

OPTIONS / SIGNALÉTIQUES



TRAITEMENT / COLORIS

7016	- RAL AU CHOIX
GALVA BRUT	- VERSION GALVA + PEINTURE ou GALVA BRUT
EFFET CORTEN	- PEINTURES SPÉCIFIQUES (Voir page 8)
INOX	- VERSION INOX (Voir références compatibles - Tarif)

**BUTON
DESIGN**



Ligne résolument moderne
aux multiples options de
formes, matières donc de
design pour une intégration
parfaite et fonctionnelle

appuis vélo - Ligne 100



DC 11 COMPACT
- Variante



OPTIONS

PM 10

PC 10

MC 10 - P 40
MC 11 - P 80 **

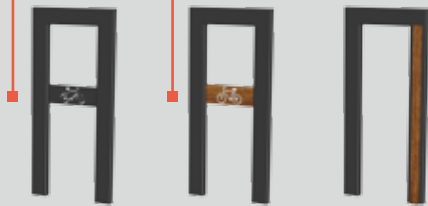

PAC 10 - L 40
PAC 11 - L 80

APPUI VÉLO AV 100

L 400 x H 900 / Tubes 80 x 40

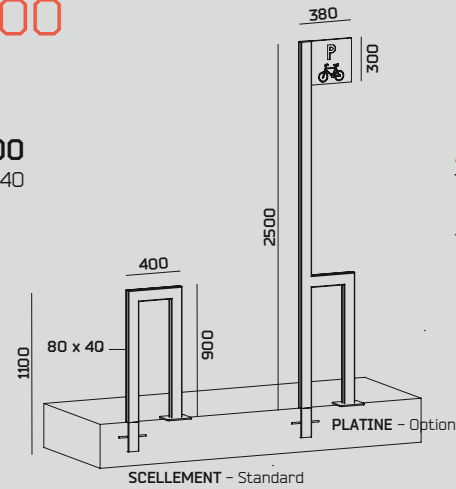

APPUI VÉLO « DRAPEAU »

Tubes 80 x 40 dont un H 2 500
DRAPEAU MÉTAL « P + VÉLO »
- Inclus

AV 110

APPUI VÉLO AV 120

L 900 x H 760 / Tubes 80 x 40



OPTIONS pour AV 120 / 121 / 122

PAC 12

MC 12 - P 40
MC 13 - P 80 **

PM 12 *



* position milieu ou partie haute / existe en compact

APPUI VÉLO AV 121

L 900 x H 900 / Tubes 80 x 40

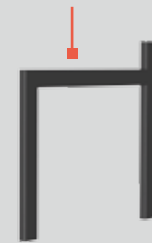

APPUI VÉLO AV 122

L 900 x H 760 / Tubes 80 x 40
Poteau bloque roue

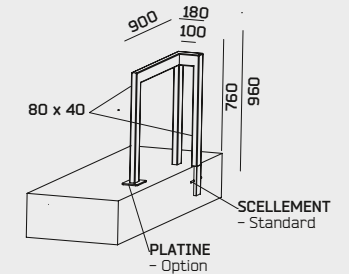
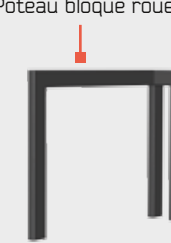

APPUI VÉLO AV 130

L 400 X H 900 / Tube 80 x 40

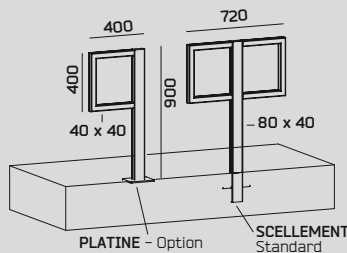

APPUI VÉLO AV 131

L 720 X H 900 / Tube 80 x 40

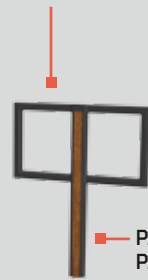

PAC 10 - L 40
PAC 11 - L 80 **

OPTIONS

PAC 10 - L 40
PAC 11 - L 80 **

DL
- DÉCOUPE LASER

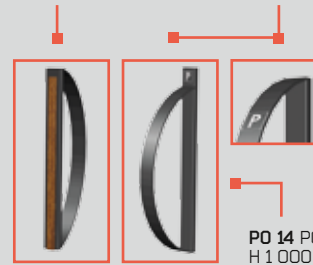

PO 14 POTEAU
H 1 000

APPUI VÉLO AV 140

400 X 900 / Tubes 80 x 40

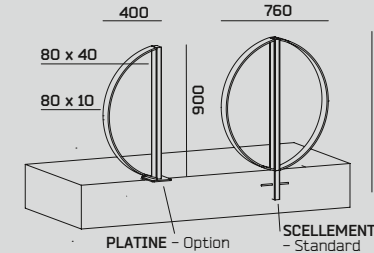

APPUI VÉLO AV 141

760 X 900 / Tubes 80 x 40



** Marquage sur demande



APPUI'S VÉLO

- Ligne 200

OPTIONS / SIGNALÉTIQUES

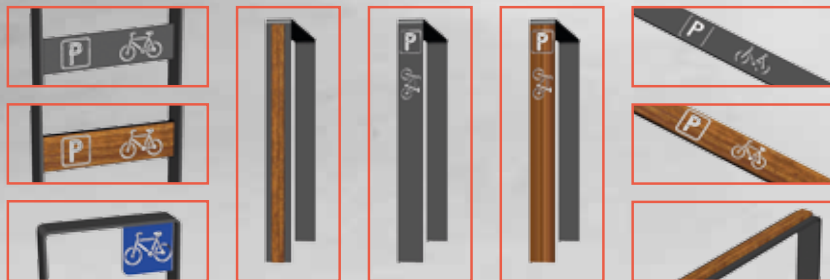

TRAITEMENT / COLORIS

7016	- RAL AU CHOIX
GALVA BRUT	- VERSION GALVA + PEINTURE ou GALVA BRUT
EFFET CORTEN	- PEINTURES SPÉCIFIQUES (Voir page 8)
INOX	- VERSION INOX (Voir références compatibles - Tarif)

**BUTON
DESIGN**



APPUI'S VÉLO aux caractéristiques épurées, nombreuses combinaisons et choix de matériaux, au service de l'esthétique et de la fonctionnalité

appuis vélo - Ligne 200

OPTIONS

PM 20 *
PLAQUE MÉTAL



PC 20 *
PANNEAU COMPACT



PM 13 **
PLAQUE MÉTAL

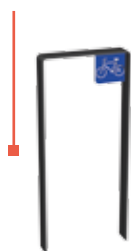

APPUI VÉLO AV 200
L 400 x H 900 / Fer plat 80 x 10

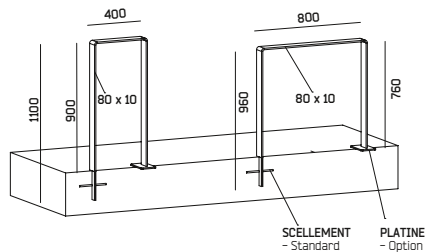

APPUI VÉLO AV 210
L 800 x H 760 / Fer plat 80 x 10

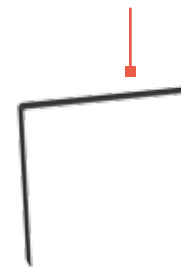

PM 21 ** - Option *
PLAQUE MÉTAL

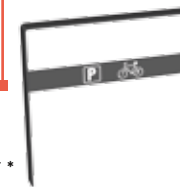

* Positionnable milieu appui ou haut appui vélo / ** Compatible sur références : AV 210 / AV 211 / AV 212

APPUI VÉLO AV 211
L 800 x H 760 / Fer plat 80 x 10
Poteau bloque roue

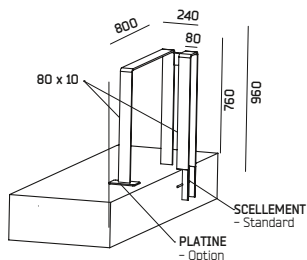
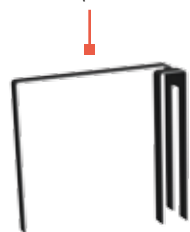

APPUI VÉLO AV 220
L 140 x H 900 / Fer plat 80 x 10

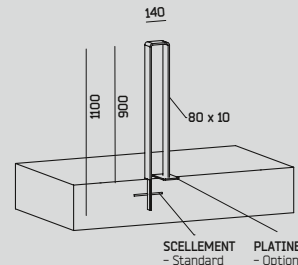

OPTIONS INTÉRIEURES - COMPATIBLES AV 212 / 220 / 230 / 231

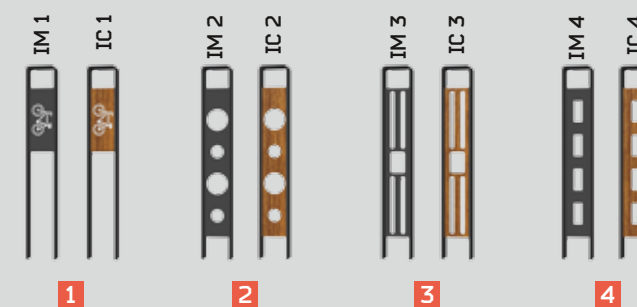

APPUI VÉLO AV 212
L 930 x H 900 / Fer plat 80 x 10

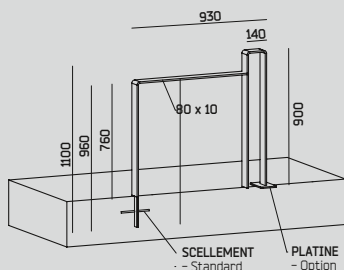
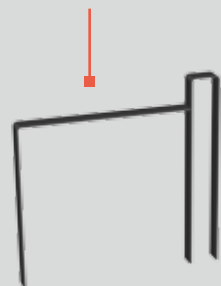

APPUI VÉLO AV 231
L 720 x H 900 / Fer plat 80 x 10

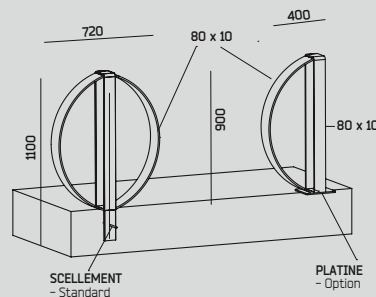

APPUI VÉLO AV 230
L 400 x H 900 / Fer plat 80 x 10

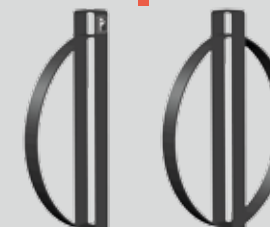

PO 23 - H 1000
DL - DÉCOUPE LASER
- Options

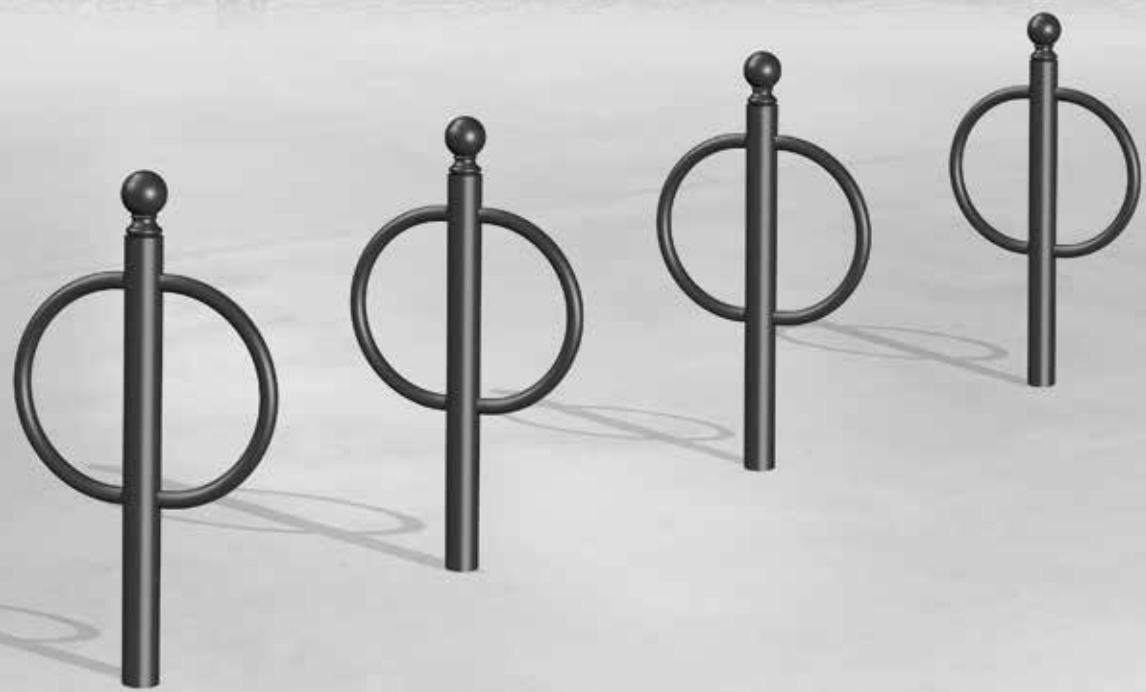

**BUTON
DESIGN**

APPONTS VÉLO - Ligne 300

Ligne au design traditionnel avec de nombreuses références aux différentes ergonomies d'utilisation pour une fonctionnalité et une intégration optimales



appuis vélo - Ligne 300

OPTION / PS 30

MAT HAUTEUR 2 400 / SIGNALÉTIQUE

VARIANTES

*TÊTE PLATE / RÉF + P

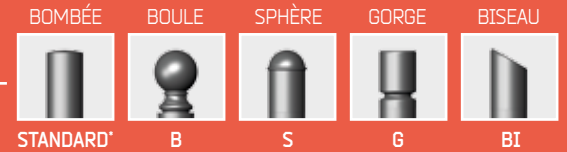

APPUI VÉLO AP 300 B

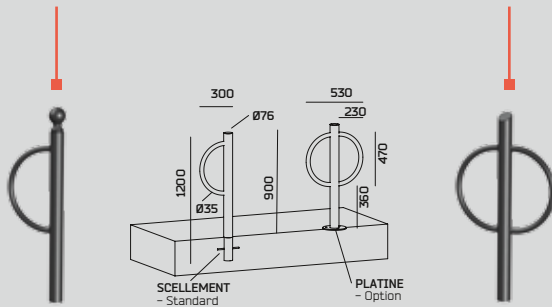

AP 301 I



AP 310 S



AP 311 G

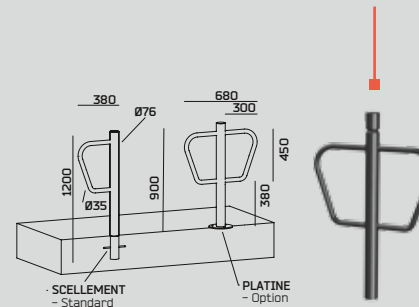

AP 320



AP 321 B

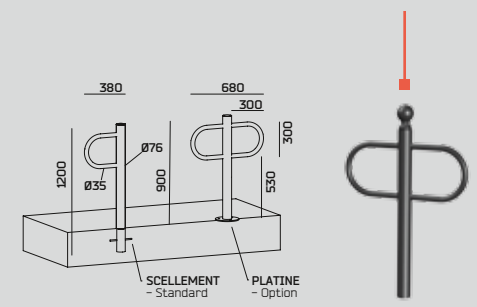

PS 30
- Option



APPUI VÉLO AP 330 B

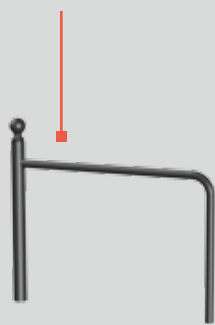

AP 330 G

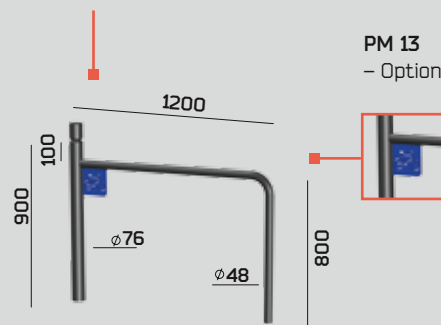

PM 13
- Option

APPUI VÉLO

AP 340 - Ø 60 / 800 x 800 AP 350 - Ø 60 / 600 x 900
AP 341 - Ø 48 / 800 x 800 AP 351 - Ø 48 / 600 x 900

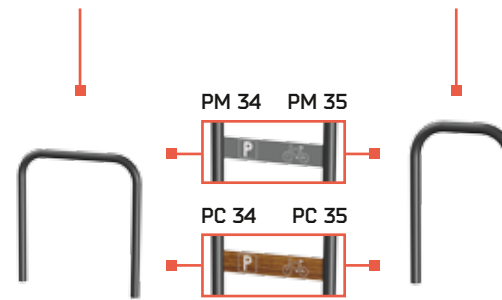

APPUI VÉLO

AP 360 - Ø 60 / 800 x 800 x 300

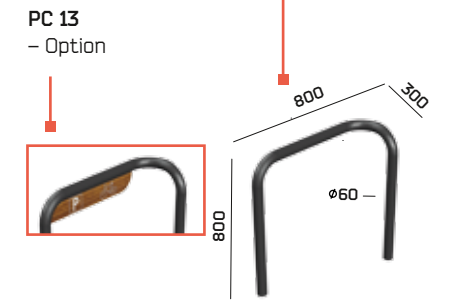

PC 13
- Option

PS 30
- Option



PORTE VÉLOS

PV 370 G - 3 places
1 000 x 520 x 320
sur Platines (PL) - Option

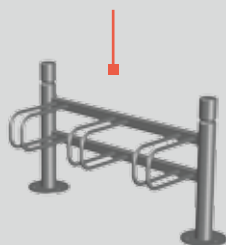

AP 371 I - 6 places (2 x 3)
000 x 520 x 610

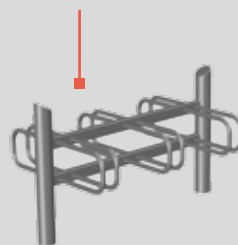

PV 380 - 6 places
2 000 x 520 x 320
sur Platines (PL) - Option

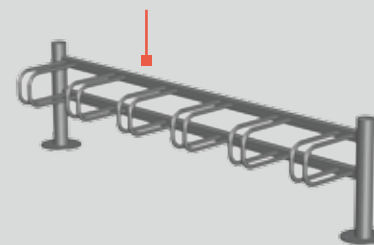

PV 381 - 12 places (2 x 6)
2 000 x 520 x 610
Piétements 70 x 70 (P70) - Option *

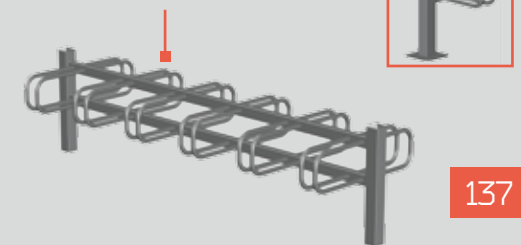

* Compatible sur toutes les références

appuis vélo - Autres

APPUI VÉLOS PV 200 / 6 Places

A cheiller

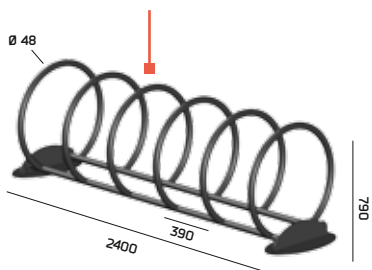

PV 27 / 5 Places

A cheiller

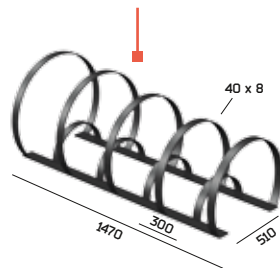

PV 20 / 4 Places (PV 20-1 / 11 Places)

A cheiller

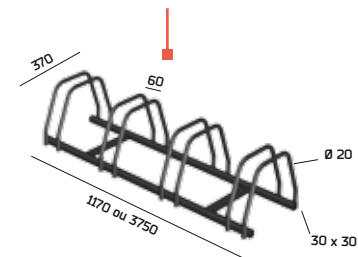

APPUIS VÉLO - Plat 40 x 10

PV 10

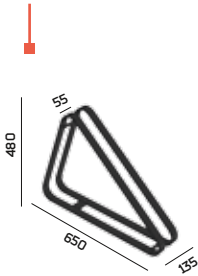

PV 11

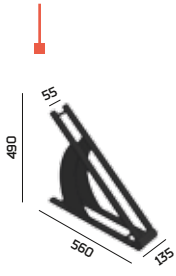

PV 12

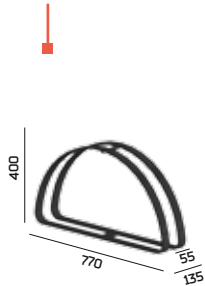

PV 29

1 Place / mural

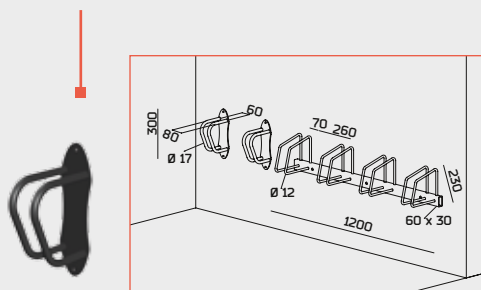

PV 21

4 Places / mural

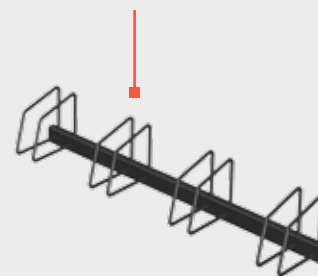

PV 30

Poteau 100 x 100 / A sceller

Equipement AP 7 (Receveur vélo - 4 maxi)

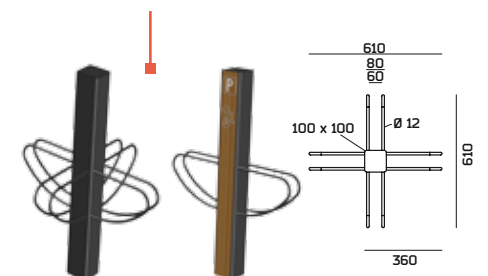

APPUIS VÉLO*

AV 10

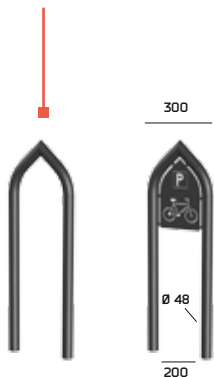

— OPTIONS
P 10
Signalétique

AV 11
Hauteur 2 400
(P 10 compris)

AV 20



P 20 - Signalétique
- Option

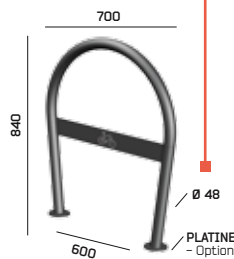

AV 30

Ep 40 / Ajouré



OPTION

PS - Peinture spécifique
- Voir page 8



AV 40

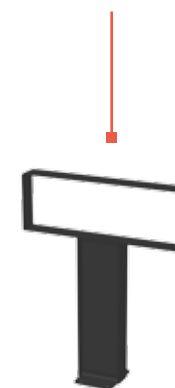

OPTIONS

PC 40 - Panneau compact

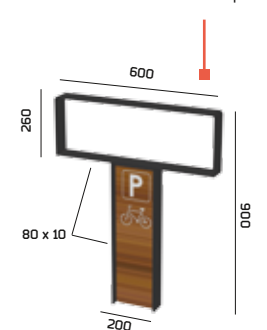

appuis moto

VARIANTES *

* AM 10 / AM 20

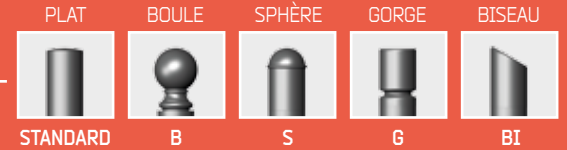

APPUI MOTO AM 10 B

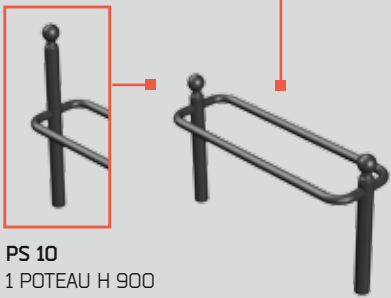

PS 10
1 POTEAU H 900
- Option



PS 30
1 POTEAU H 2 400
- Option

AM 10 IC 10 INTÉRIEUR COMPACT - Option

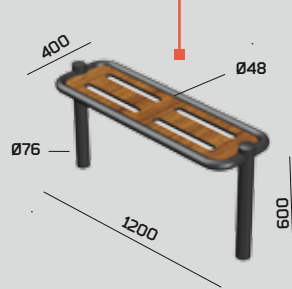

APPUI MOTO AM 20 G *

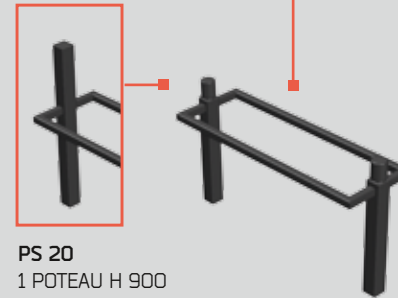

PS 20
1 POTEAU H 900
- Option



PS 24
- Option

AM 20 IC 20 INTÉRIEUR COMPACT - Option

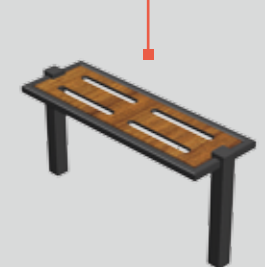

* Dimensions idem AM 10

APPUI MOTO AM 30

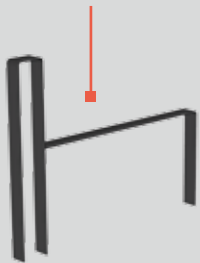

APPUI MOTOS AM 31

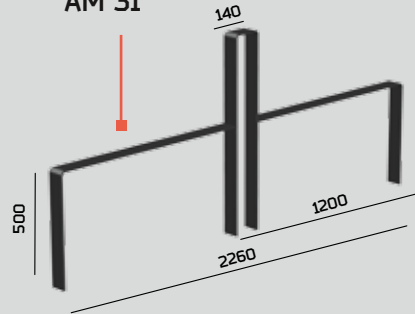

OPTIONS

DL
DECOUPE LASER



MC 30 - L40
MC 31 - L80

PAC 23
L80



OPTIONS INTÉRIEURES

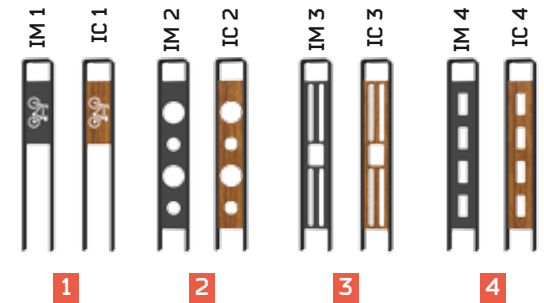

APPUI MOTO AM 40

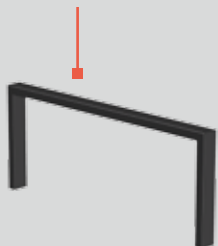

PM 40
- Option

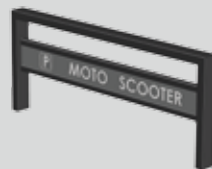

PC 40
- Option

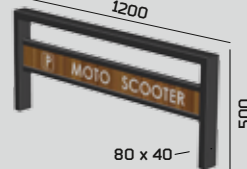

PS 40
1 POTEAU H 900
- Option



AM 40 + PS 40

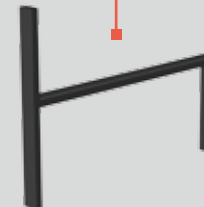

OPTIONS HABILLAGES



PAC 22 - L40
PAC 23 - L80



PAC 40 - L40
PAC 41 - L80



MC 40 - L40
MC 41 - L80