

balı



**BUTON
DESIGN**

Ligne où les matériaux utilisés expriment
toutes leurs capacités en terme
d'esthétisme, d'ergonomie et de qualité



DESCRIPTIF	Ligne composée d'assises / de dossiers, en stratifié compact aux multiples esthétiques, avec finition arrondie ou anguleuse.
PIÈTEMENT	Acier Ø 90 mm / Finitions : peint (grenailage + apprêt époxy + peinture polyester cuite au four à 200°C) RAL AU CHOIX
ASSISE / DOSSIER	Compact : effet lames droites ou arrondies / Finitions : COLORIS AU CHOIX selon nuancier page 10
POSE / FIXATION	À cheviller ou à sceller (piètements + 200 mm). LIVRÉ NON MONTÉ

VARIANTES

- PIÈTEMENTS (+ 200 mm) POUR SCELLEMENT
- PEINTURES SPÉCIFIQUES – Voir page 10
- GALVANISATION AVANT PEINTURE
- GALVANISATION SEULE

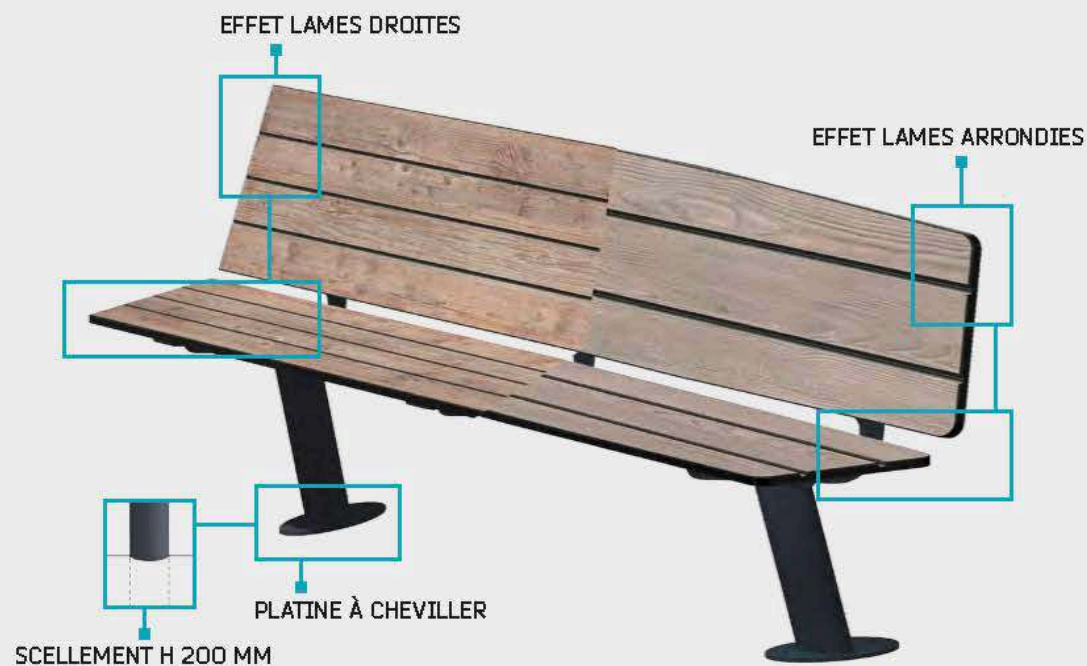

BANC

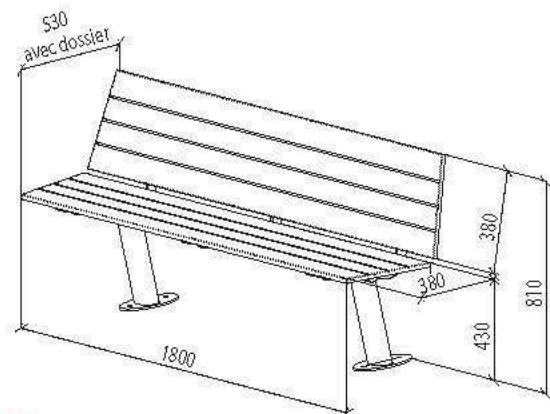

BANQUETTE

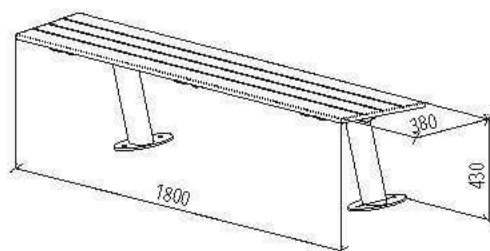

BANQUETTE INDIVIDUELLE

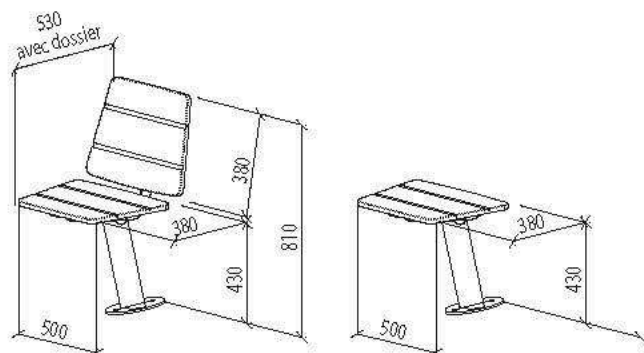

BC 31 EL

L1800 - ASSISE ET DOSSIER EN COMPACT EFFET LAMES DROITES



BC 41 EL

L1800 - ASSISE ET DOSSIER EN COMPACT EFFET LAMES ARRONDIES



BA 31 EL
L1800 - ASSISE EN COMPACT EFFET LAMES DROITES



BI 31 EL
L500 - ASSISE ET DOSSIER
EN COMPACT EFFET LAMES DROITES



BAI 31 EL
L500 - ASSISE EN COMPACT
EFFET LAMES DROITES



BA 41 EL
L1800 - ASSISE EN COMPACT EFFET LAMES ARRONDIES



BI 41 EL
L500 - ASSISE ET DOSSIER
EN COMPACT EFFET LAMES ARRONDIES



BAI 41 EL
L500 - ASSISE EN COMPACT
EFFET LAMES ARRONDIES