

# berlin



**BUTON  
DESIGN**

Pureté des lignes, qualité des matériaux pour une  
intégration parfaite.



<b>DESSCRIPTIF</b>	Ligne composée d'assises et dossiers en stratifié compact et/ou acier métal
<b>PIÈTEMENT</b>	Acier 70 x 35 mm / Finition : peint (grenailage + apprêt époxy + peinture polyester cuite au four à 200°C). <b>RAL AU CHOIX</b>
<b>ASSISE / DOSSIER</b>	Compact : lames, compact plein / Acier : ajouré, tube 70 x 35 / Découpe laser / Finitions : <b>COLORIS AU CHOIX</b> selon nuancier page 10
<b>POSE / FIXATION</b>	À cheviller ou à sceller (piètements + 200 mm). <b>LIVRÉ NON MONTÉ</b>

## VARIANTES

- BANDEAU (Compact ou acier) SUR DEVANT DE L'ASSISE
- PIÈTEMENTS (+ 200 mm) POUR SCELLEMENT
- ACCOUDOIRS
- PEINTURES SPÉCIFIQUES – Voir page 10
- GALVANISATION AVANT PEINTURE

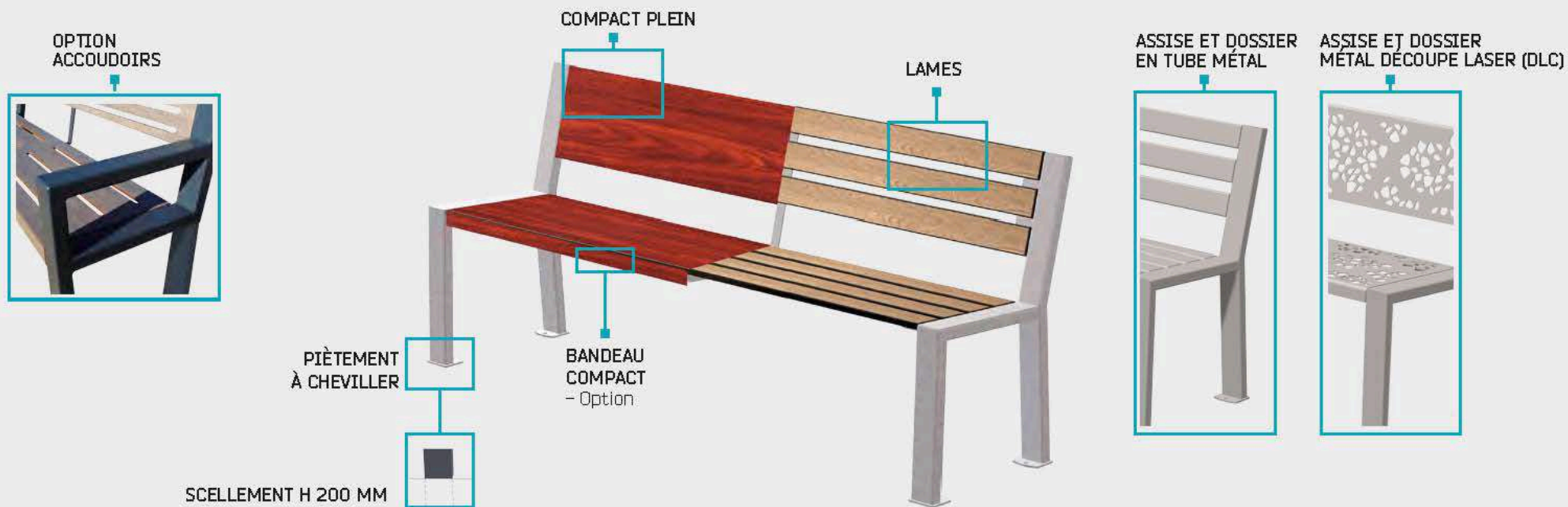

### BANC

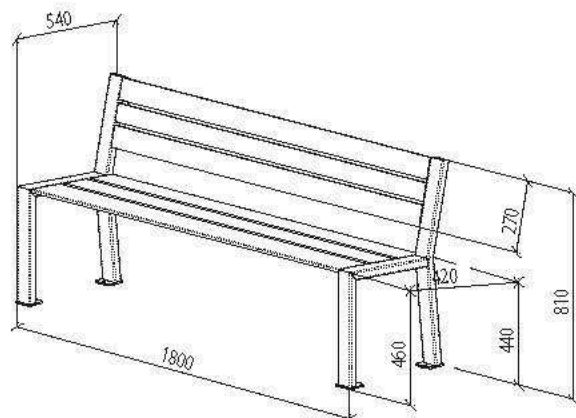

### BANQUETTE

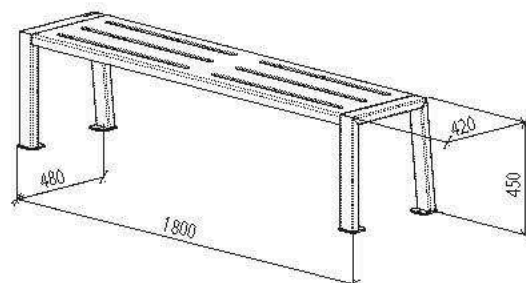

### BANQUETTE INDIVIDUELLE

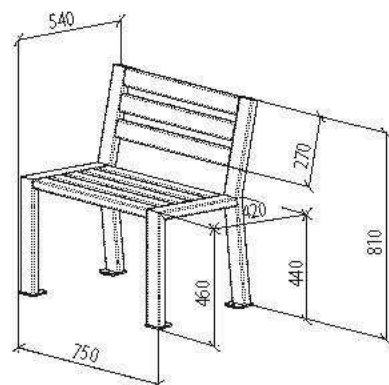

**BC 80**

L1800 - ASSISE ET DOSSIER EN LAMES DE COMPACT



**BC 80-CP**

L1800 - ASSISE ET DOSSIER EN COMPACT PLEIN



# ASSISES - berlin



**BA 80**  
L1800 - ASSISE EN LAMES DE COMPACT



**BI 80**  
L750 - ASSISE ET DOSSIER EN LAMES DE COMPACT



**BAI 80**  
L750 - ASSISE EN LAMES DE COMPACT



**BA 80-CP**  
L1800 - ASSISE EN COMPACT PLEIN



**BI 80-CP**  
L750 - ASSISE ET DOSSIER EN COMPACT PLEIN



**BAI 80-CP**  
L750 - ASSISE EN COMPACT PLEIN

### BANC

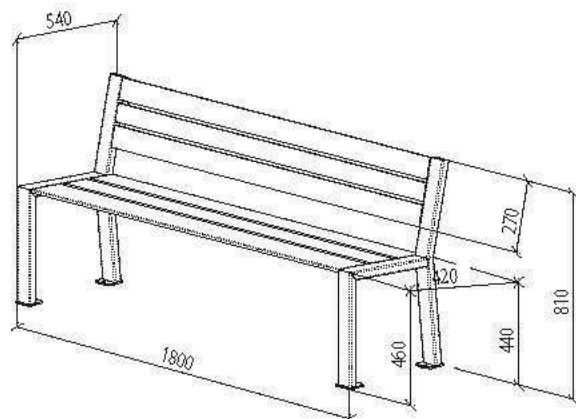

### BANQUETTE

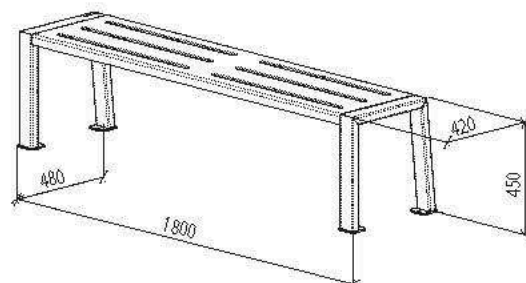

### BANQUETTE INDIVIDUELLE

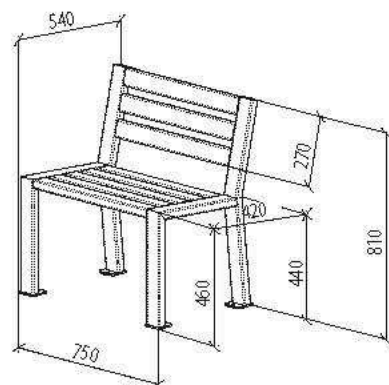

**BC 80 TU**

L1800 - ASSISE ET DOSSIER EN TUBE 70X35



**BC 80 DLC**

L1800 - ASSISE ET DOSSIER EN MÉTAL AVEC DÉCOUPE LASER



# ASSISES - berlin

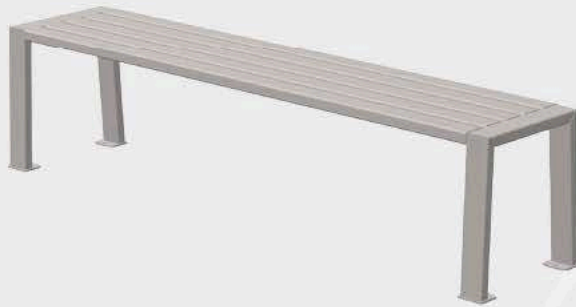

**BA 80 TU**  
L1800 - ASSISE EN TUBE 70X35



**BI 80 TU**  
L750 - ASSISE ET DOSSIER EN TUBE 70X35



**BAI 80 TU**  
L750 - ASSISE EN TUBE 70X35



**BA 80 DLC**  
L1800 - ASSISE EN MÉTAL AVEC DÉCOUPE LASER



**BI 80 DLC**  
L750 - ASSISE ET DOSSIER EN MÉTAL  
AVEC DÉCOUPE LASER



**BAI 80 DLC**  
L750 - ASSISE EN MÉTAL AVEC DÉCOUPE LASER