



APPUI'S VÉLO

- Ligne 100

OPTIONS / SIGNALÉTIQUES



TRAITEMENT / COLORIS

- 7016** - RAL AU CHOIX
- GALVA BRUT** - VERSION GALVA + PEINTURE ou GALVA BRUT
- EFFET CORTEN** - PEINTURES SPÉCIFIQUES (Voir page 8)
- INOX** - VERSION INOX (Voir références compatibles - Tarif)

**BUTON
DESIGN**



Ligne résolument moderne aux multiples options de formes, matières donc de design pour une intégration parfaite et fonctionnelle

appuis vélo - Ligne 100

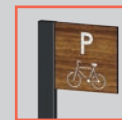

DC 11 COMPACT
- Variante



AV 110

OPTIONS

PM 10



PC 10



MC 10 - P 40
MC 11 - P 80 **



PAC 10 - L 40
PAC 11 - L 80

APPUI VÉLO AV 100

L 400 x H 900 / Tubes 80 x 40

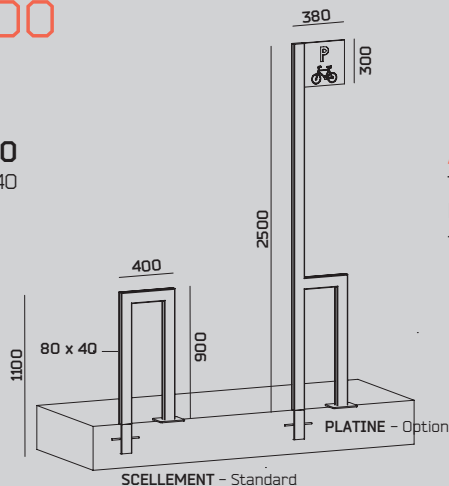

APPUI VÉLO « DRAPEAU »

AV 110
Tubes 80 x 40 dont un H 2 500
DRAPEAU MÉTAL « P + VÉLO »
- Inclus

APPUI VÉLO AV 120

L 900 x H 760 / Tubes 80 x 40



OPTIONS pour AV 120 / 121 / 122

PAC 12



MC 12 - P 40
MC 13 - P 80 **



PM 12 *

* position milieu ou partie haute / existe en compact

APPUI VÉLO AV 121

L 900 x H 900 / Tubes 80 x 40



APPUI VÉLO AV 122

L 900 x H 760 / Tubes 80 x 40
Poteau bloque roue

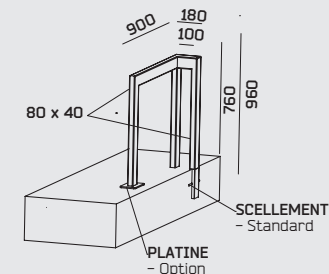
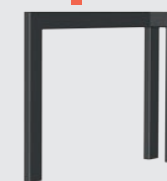

APPUI VÉLO AV 130

L 400 X H 900 / Tube 80 x 40

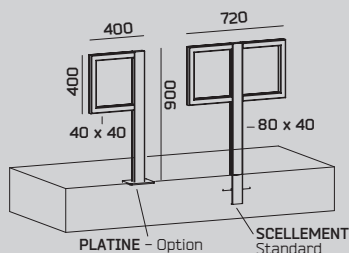

APPUI VÉLO AV 131

L 720 X H 900 / Tube 80 x 40

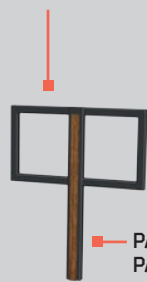

PAC 10 - L 40
PAC 11 - L 80 **

OPTIONS

PAC 10 - L 40
PAC 11 - L 80 **

DL
- DÉCOUPE LASER



PO 14 POTEAU
H 1 000

APPUI VÉLO AV 140

400 X 900 / Tubes 80 x 40

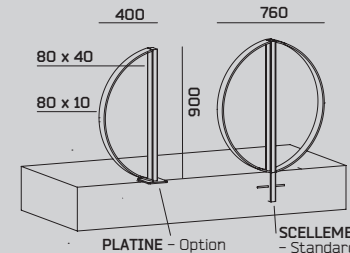

APPUI VÉLO AV 141

760 X 900 / Tubes 80 x 40



** Marquage sur demande